



*ACE 2011 International*

# Why Document Management Isn't Enough

- ▶ Eric Smith, Razorleaf
- ▶ [www.Razorleaf.com](http://www.Razorleaf.com)



# Agenda

- ▶ **History Lesson**
- ▶ **Defining BOM Management**
- ▶ **Why Change?**
- ▶ **How BOM Management Works**
- ▶ **Organizational Impact**
- ▶ **Example**





# Learning from Abiogenesis

## ▶ The simple model

- 'life spontaneously develops out of nothing'
- There was evidence
- But there were contradictions



*Louis Pasteur*

## ▶ The complex model

- Microbiology
  - ...which yielded germ theory and vaccinations

**Sometimes the complex answer is better**



# CONNECT-THE-DOTS!

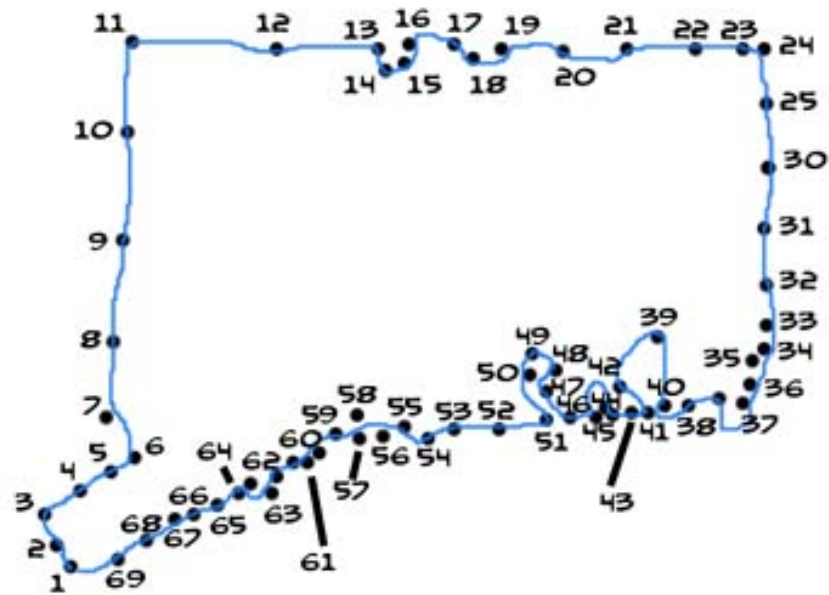

# PLM and Abiogenesis

## ▶ Document Mgmt is like abiogenesis

- Simple/basic model
- Easily understood
- Well accepted

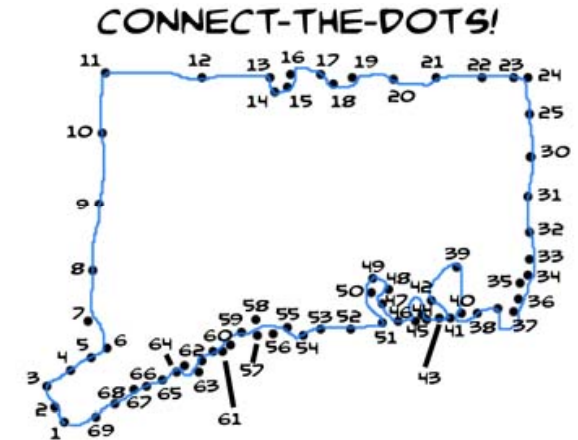

## ▶ BOM Mgmt is like microbiology and germ theory

- Complex
- Better model of reality

**Sometimes the complex answer is better**



# Part Management

# Document Management

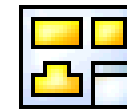
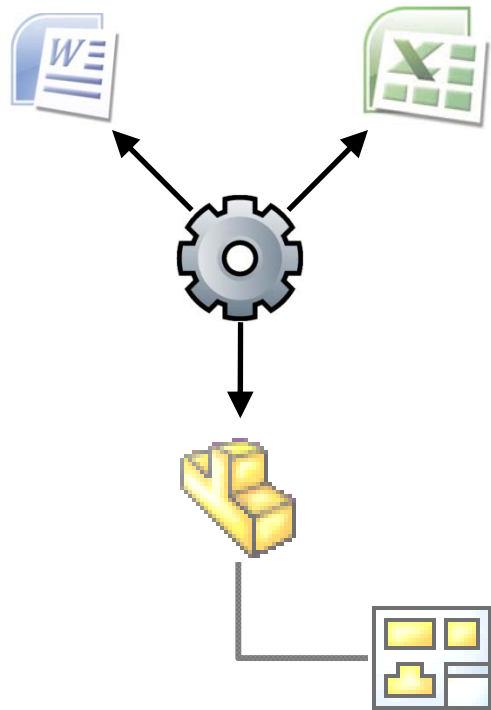

# Part Management

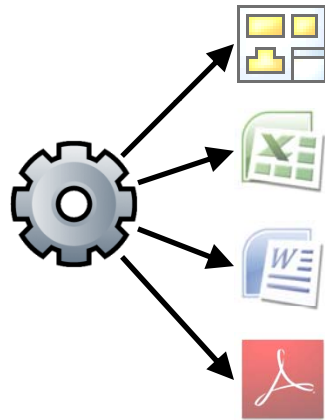

# Document Management

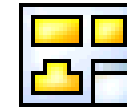

# BOM Management

# Document Management

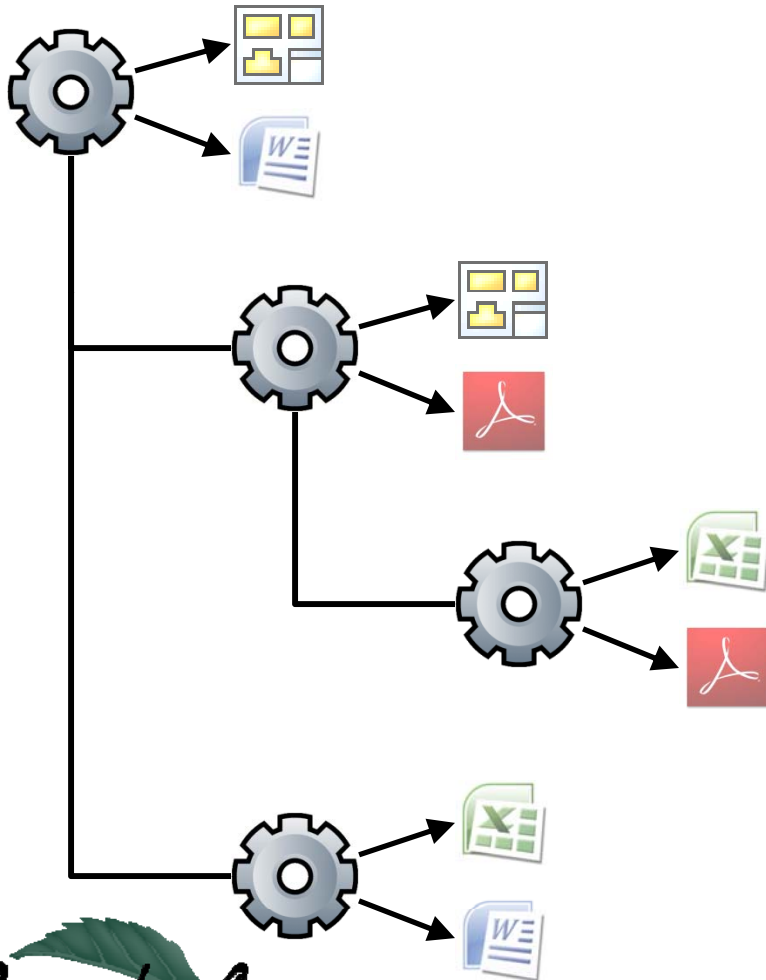

# Why Change?

## ▶ Drawing Revision is insufficient:

- Describing status and maturity with revisions is *hard*

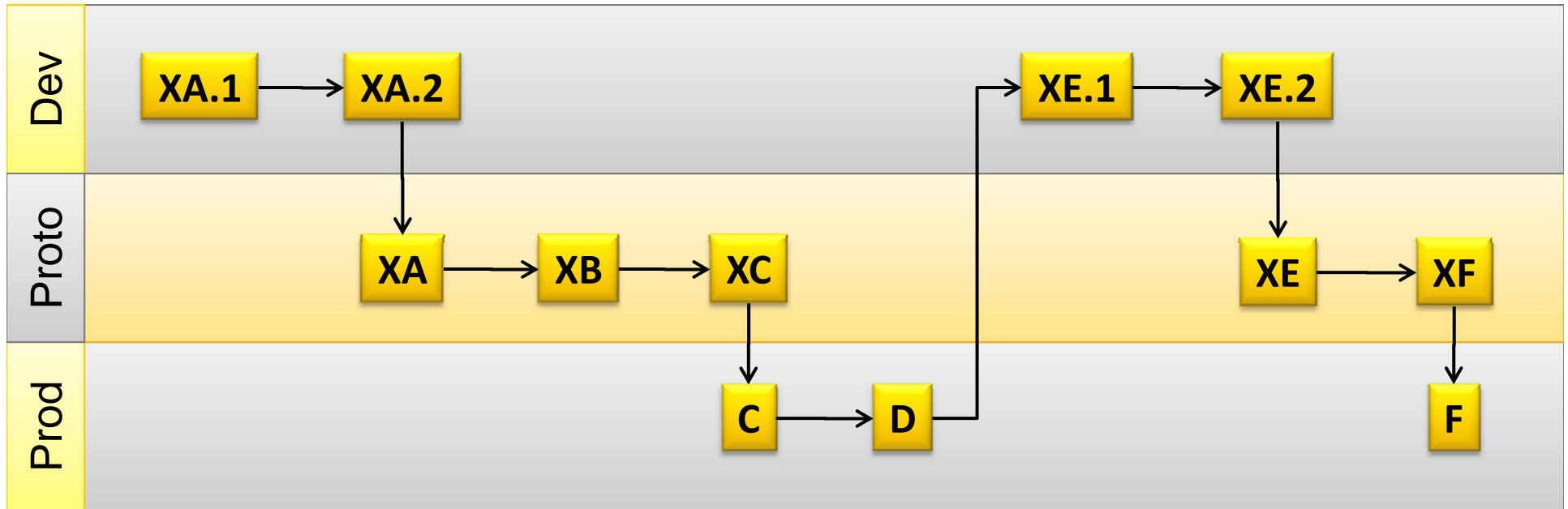

# Why Change?

## ▶ Drawing Revision is insufficient:

- Describing status and maturity
- Change stacking

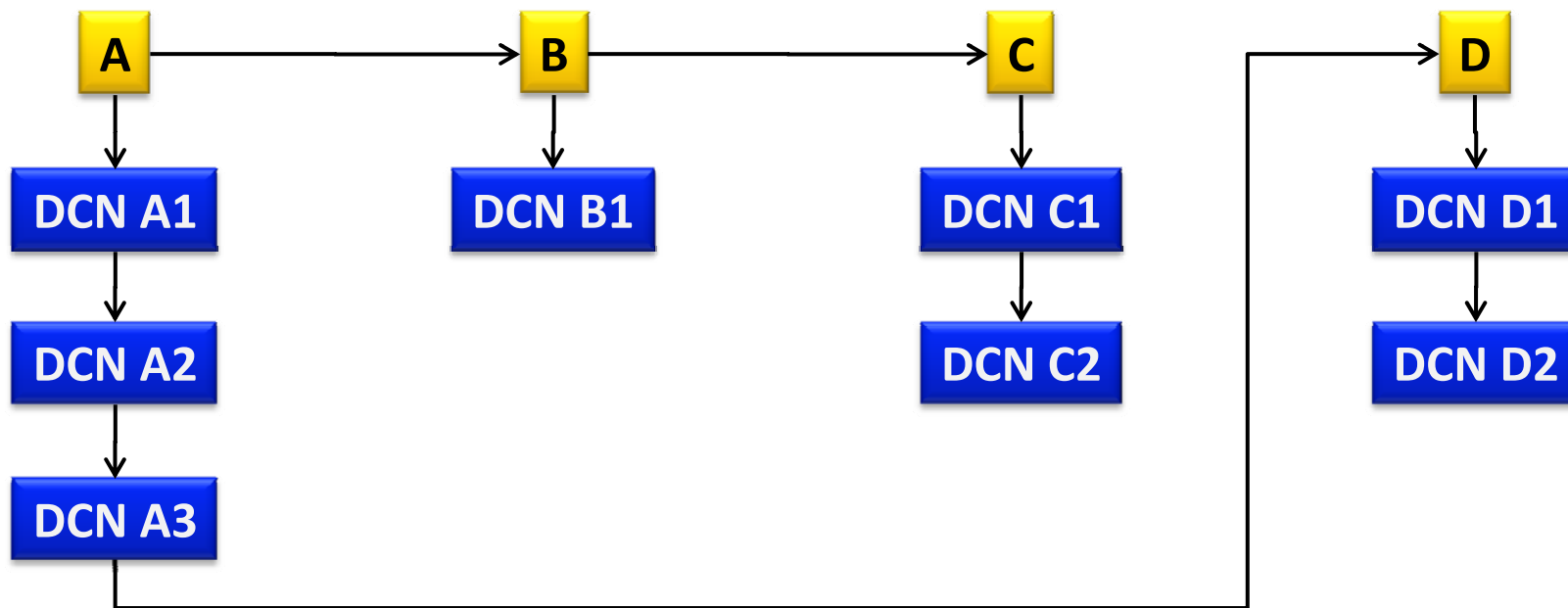

# Why Change?

## ▶ Drawing Revision is insufficient:

- Describing status and maturity
- Change stacking
- N parts on 1 drawing

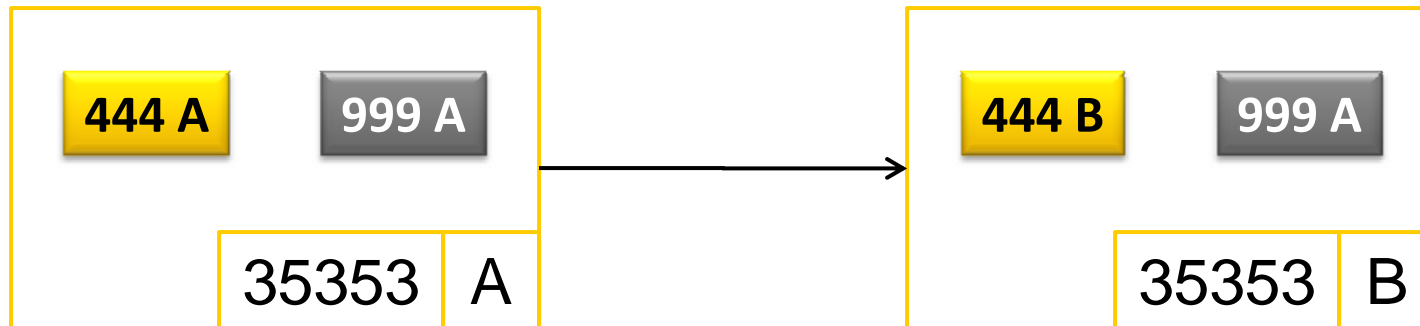

# Why Change?

- ▶ CAD is a barrier to collaboration
  - CAD = Top Secret protection?

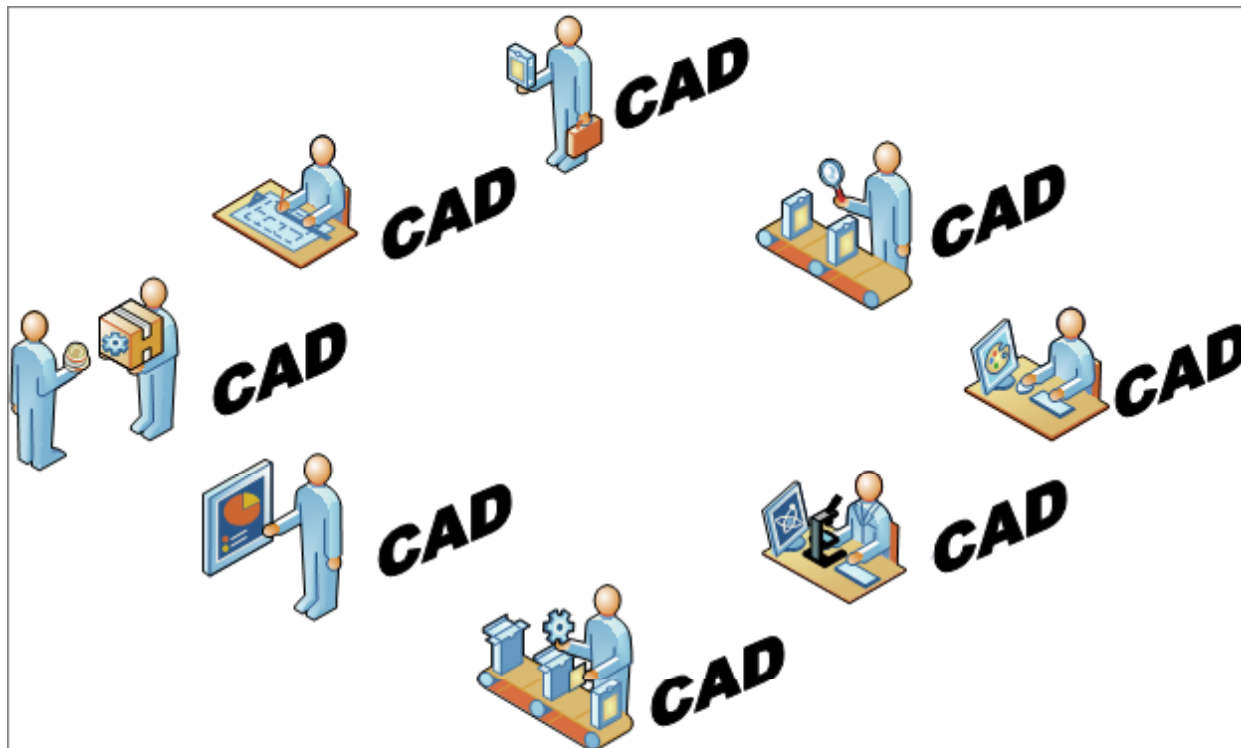

# Why Change?

- ▶ CAD is a barrier to collaboration
  - CAD = Top Secret protection?

**TOP SECRET**

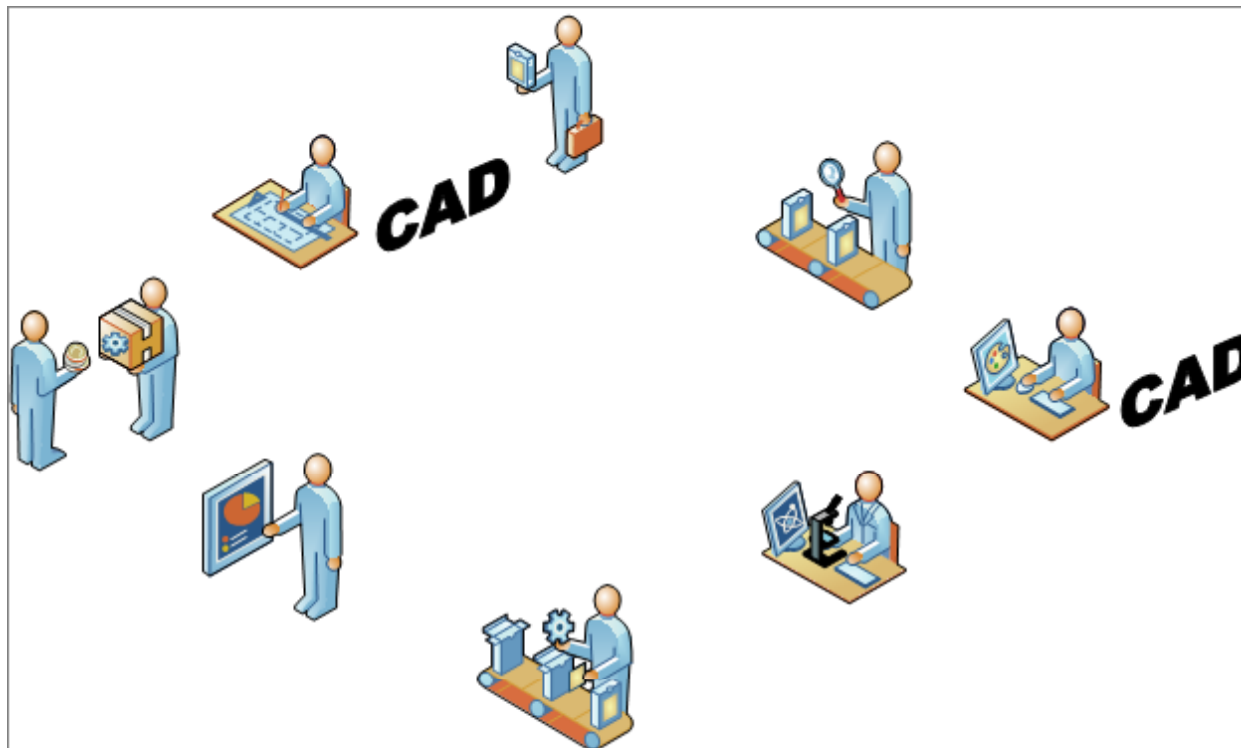

# Why Change?

## ▶ CAD is a barrier to collaboration

- CAD = Top Secret protection?
- What do people use to collaborate instead?

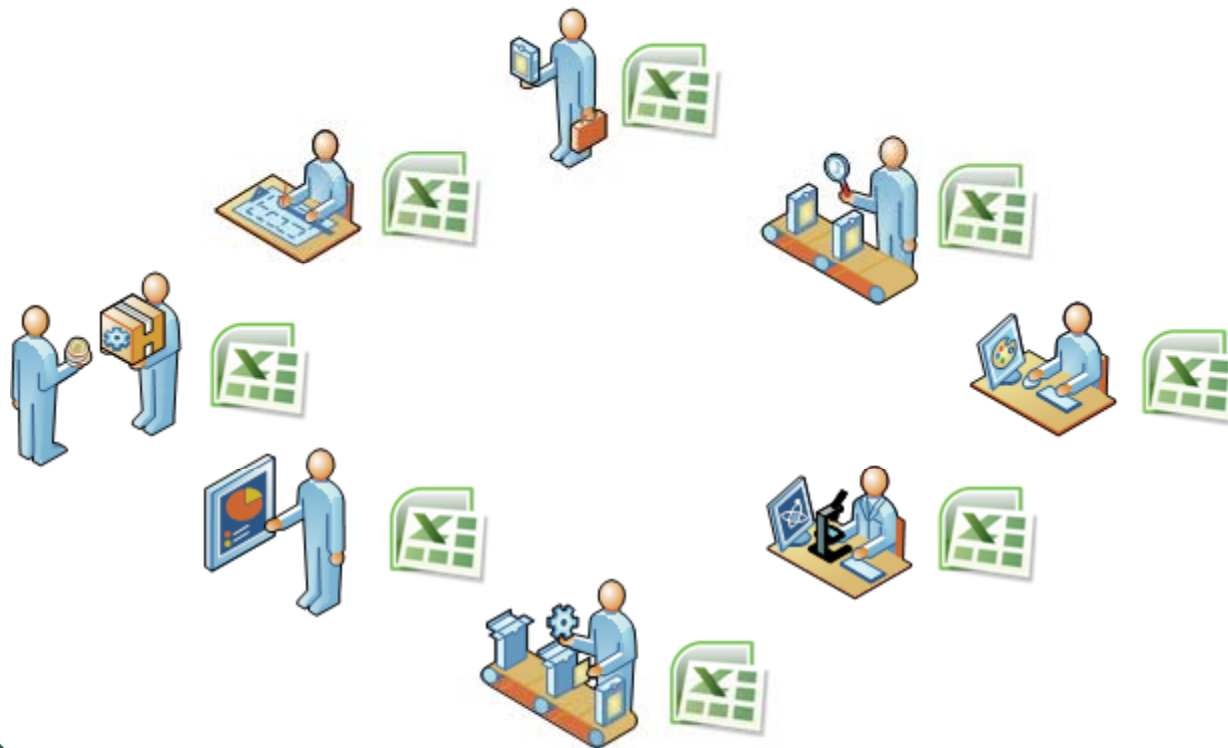

# Why Change?

## ▶ Added flexibility

- “Model” products quickly
- Avoid non-value-add during change
  - Mass note updates
  - Full ECx approvals for clerical fixes



# How Does It Work?

## ▶ Separate Parts from Documents

- Parts get their own identifiers (PN and Rev)

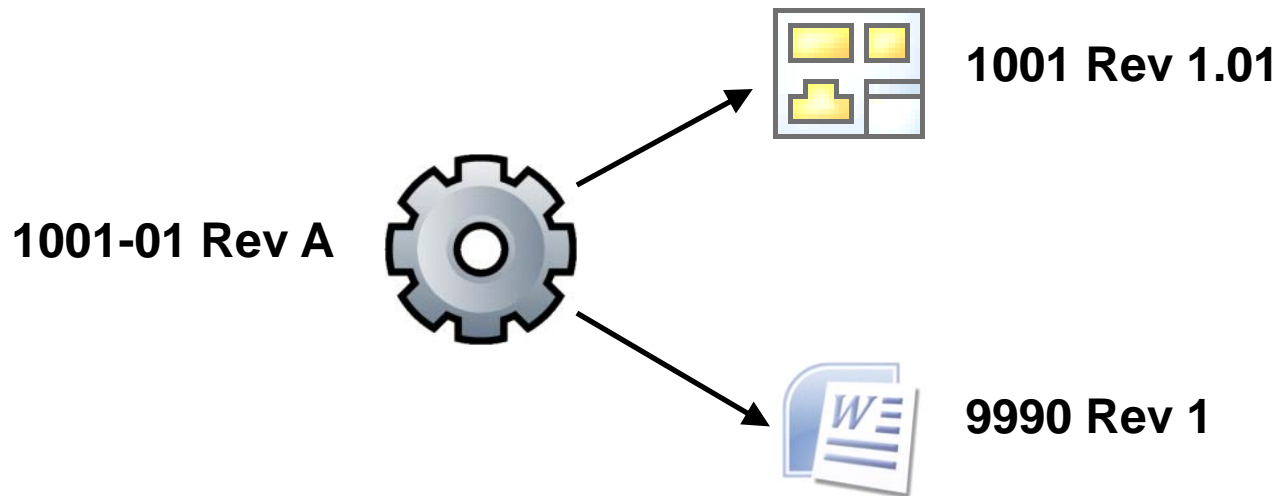

# How Does It Work?

## ▶ Separate Parts from Documents

- Parts get their own identifiers (PN and Rev)
- Parts get their own maturity

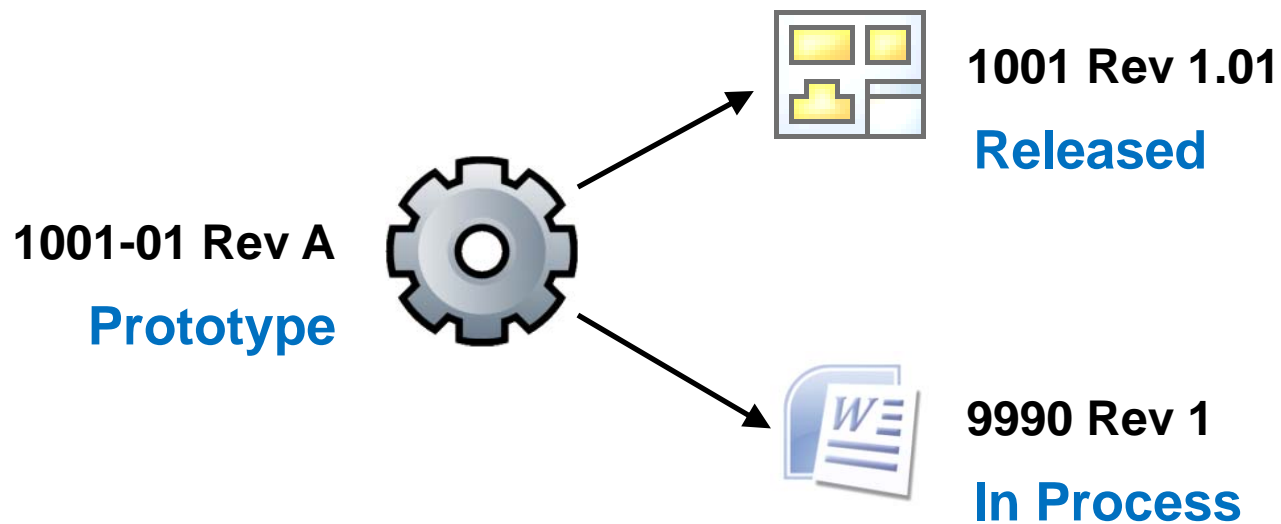

# How Does It Work?

## ▶ Separate Parts from Documents

- Parts get their own identifiers (PN and Rev)
- Parts get their own maturity
- Parts and Documents get Rev specific links

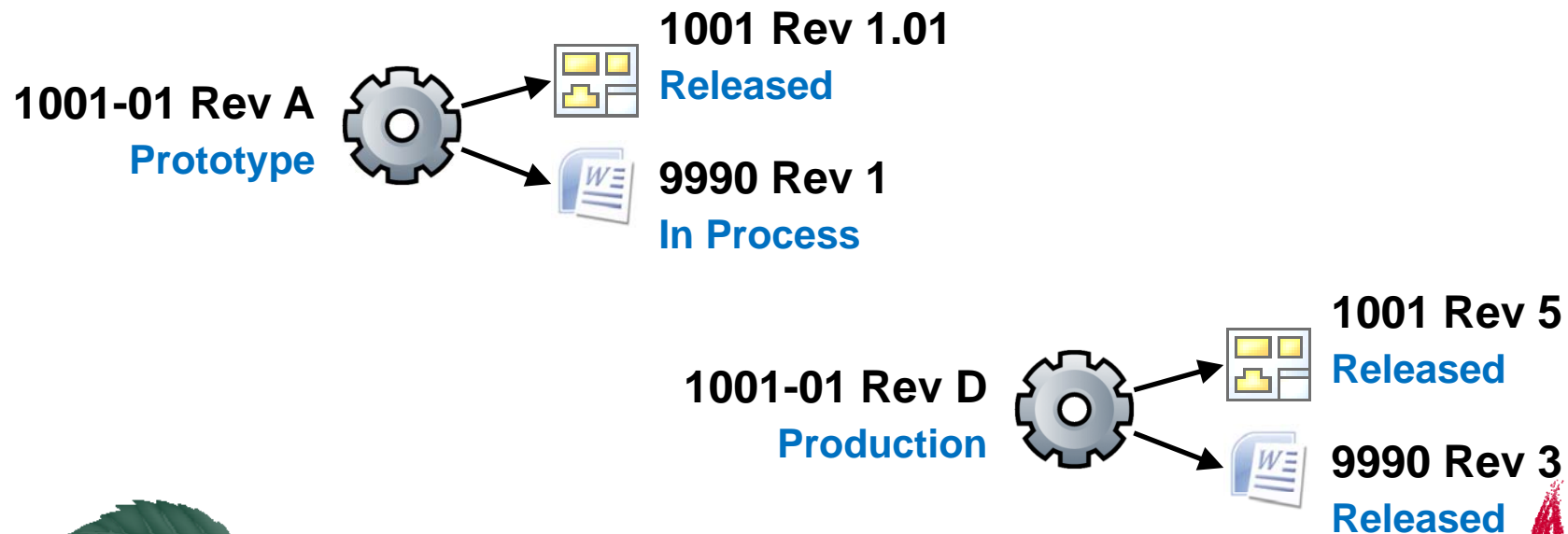

# How Does It Work?

## ▶ Part maturity models reality, relates to Document maturity

### ■ Part states:

- Development = in development, not ready to be made
- Prototype = you can make one, but design isn't vetted
- Approved = design finalized
- Production = ready to be made in volume
- Superseded = only for legacy product support
- Inactive = not to be made

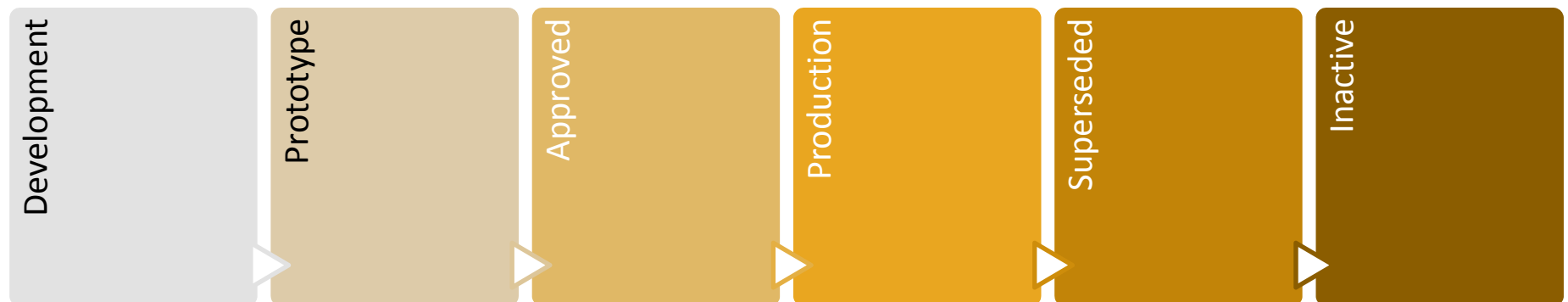

# How Does It Work?

## ▶ Part maturity models reality, relates to Document maturity

- Part states: Development, Prototype, Approved, Production, Superseded, Inactive, etc.
- Related Document maturity rules:
  - Can't promote to Approved until Documents are all Released
  - Can't change linked Docs after Part reaches Approved state



# How Does It Work?

## ▶ Part maturity models reality, relates to Document maturity

- Part states: Development, Prototype, Approved, Production, Superseded, Inactive, etc.
- Related Document maturity rules
- Part maturity rules, too:
  - Minimum child state (Approved Parts can't have Temporary children)
  - Production Parts must have Production children



# How Does It Work?



- ▶ **Engineering Change operates on Parts, Documents, or Both**
  - Simple design change
    - Rev Document, Rev Part



# How Does It Work?



## ▶ Engineering Change operates on Parts, Documents, or Both

- Simple design change
  - Rev Document, Rev Part
- Broad design improvement
  - Rev Document, Mass Change Parts



# How Does It Work?



## ▶ Engineering Change operates on Parts, Documents, or Both

- Simple design change
  - Rev Document, Rev Part
- Broad design improvement
  - Rev Document, Mass change Parts
- Upgrade design using other existing designs
  - Rev Parts Only



# How Does It Work?



## ▶ Engineering Change operates on Parts, Documents, or Both

- Simple design change
  - Rev Document, Rev Part
- Broad design improvement
  - Rev Document, Mass Change Parts
- Upgrade design using other existing designs
  - Rev Parts Only
- Fix non-substantive error
  - Rev Document, Adjust Part



# How Does It Work?



- ▶ Engineering Change operates on Parts, Documents, or Both
- ▶ Non-conformances, Deviations, and other processes operate on Parts, Documents, or Both



# Organizational Impact

## ▶ People will hate this

- “Too complicated”
- “More work”
- “Systems can’t handle it”



# Organizational Impact

▶ People will hate this

▶ Reality?

- The situation is complicated
- People are already doing this work
- Systems need to be updated to support business processes



# Organizational Impact

- ▶ People will hate this
- ▶ Reality?
- ▶ **Bonus – roles become clearer**
  - I never understood why a Buyer had to approve a spelling fix
  - The Drafter owns the drawing, not the Engineering Manager
  - Who owns the drawing, Manufacturing or Engineering?



# Organizational Impact



## ► Communication improves

- From: “Can you find me the drawing for...”  
To: ***“I can find my own drawings now.”***
- From: “I wish I could have seen what you guys were planning earlier in the process”  
To: ***“Check the system to see my idea”***
- From: “I don’t understand what happened on this ECO, can you explain it to me?”  
To: ***“I see the affected and replacement Parts, and also which Documents changed.”***



# Organizational Impact

## ▶ Product data now has a center-of-gravity

- It never made sense to link everything to the Drawing
- You can link everything to the Part:
  - Drawings
  - 3D models
  - Material specs
  - CNC code
  - Tooling drawings & models
  - Calculations & analysis
  - Assembly instructions

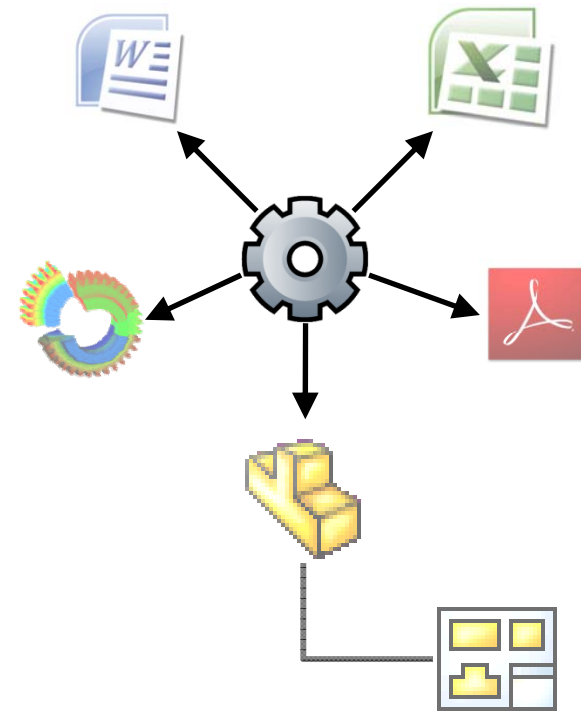

# Scenario Preview

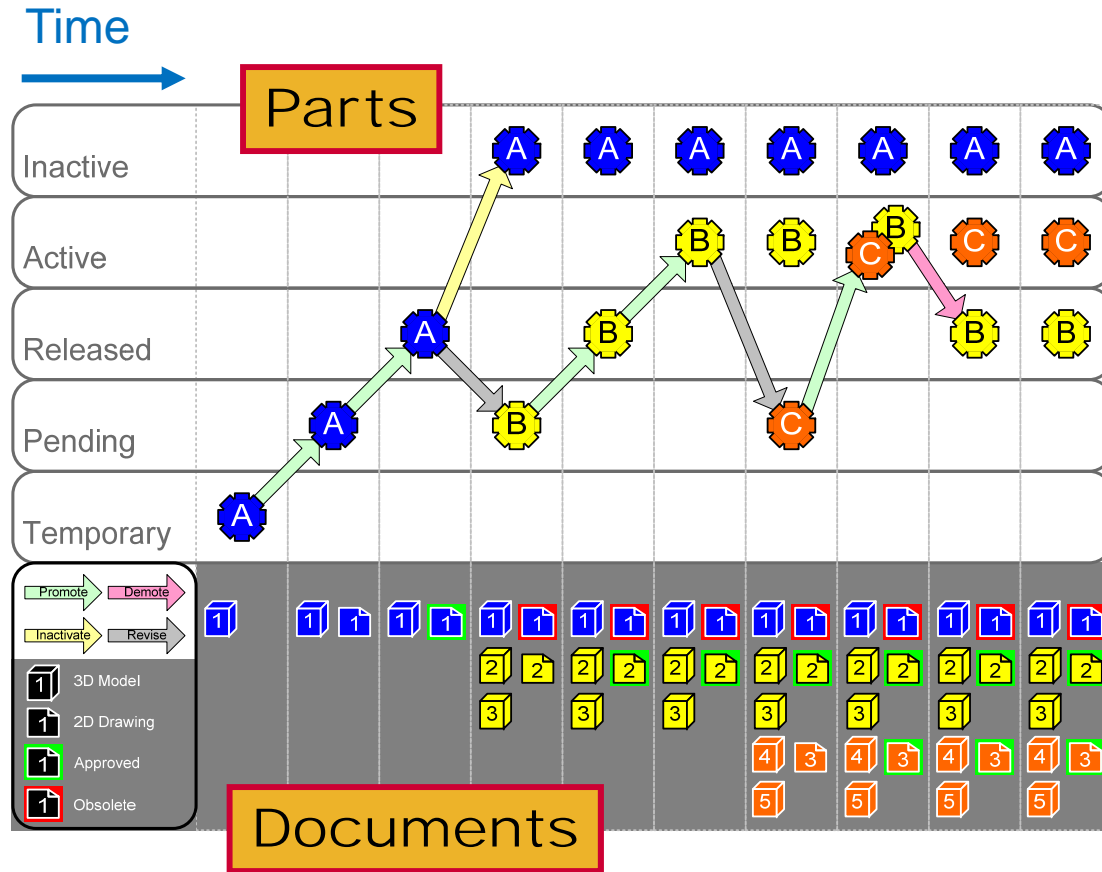

# Scenario

- ▶ Engineer with a new idea creates a 3D model
- ▶ Part created as Temporary while the concept is reviewed

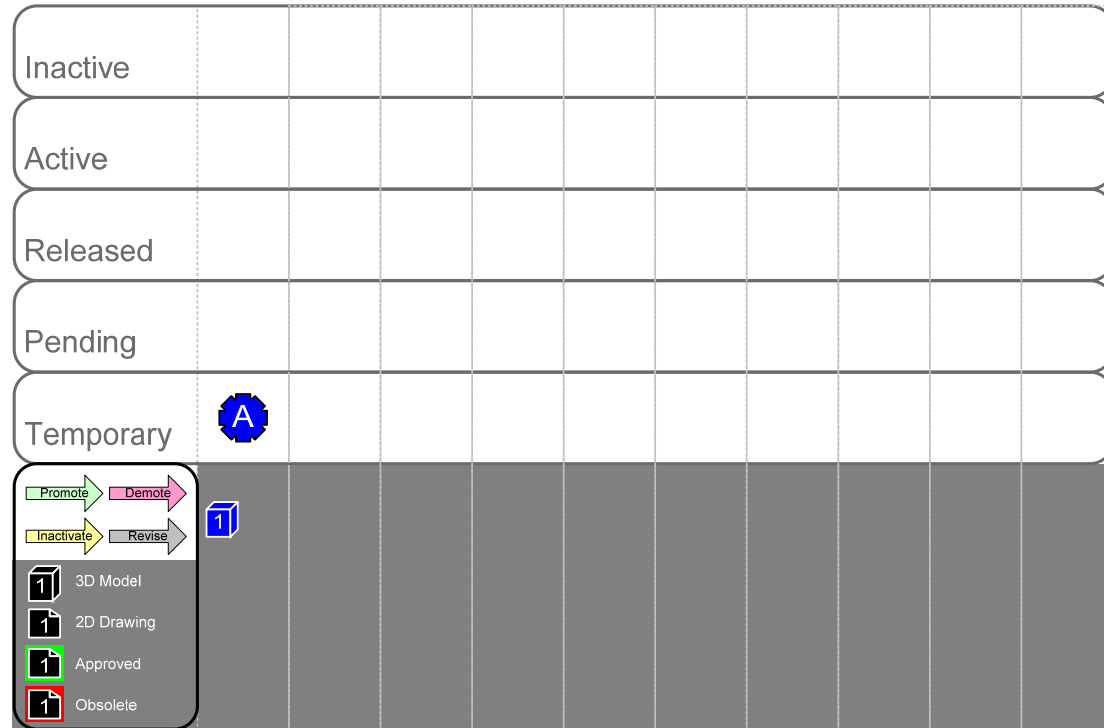

# Scenario

- ▶ Specifying drawing created
- ▶ Part set as “pending” and given part number

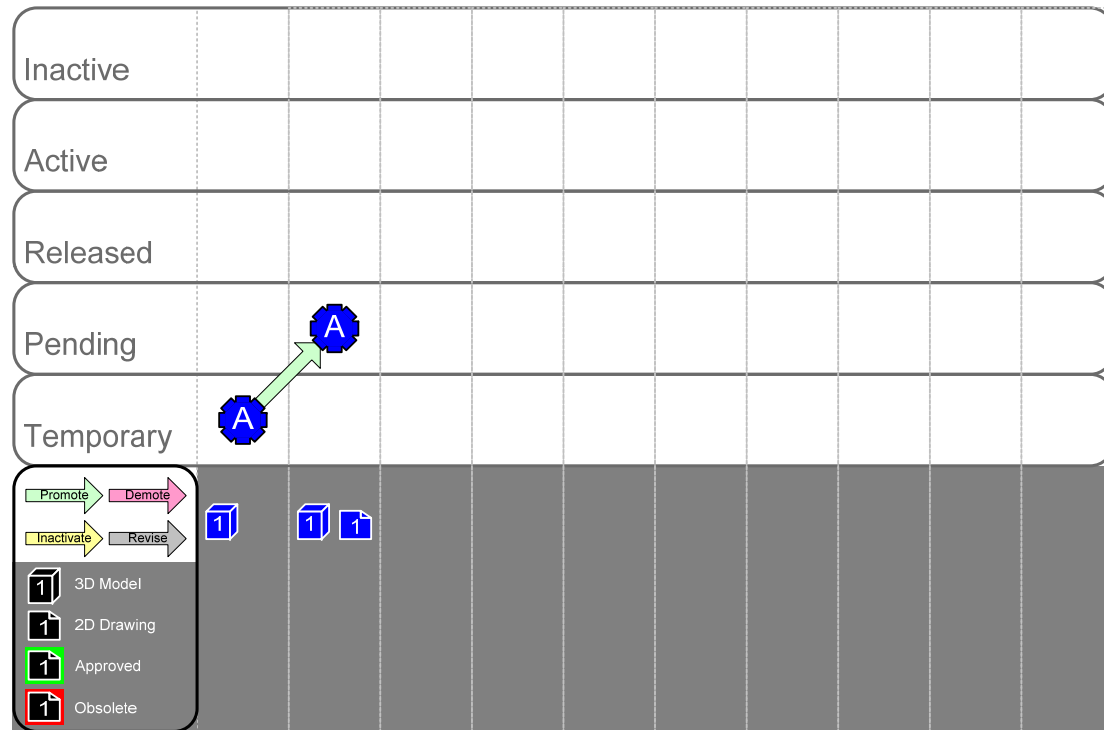

# Scenario

- ▶ Specifying drawing approved
- ▶ Pending Part promoted to state “released”

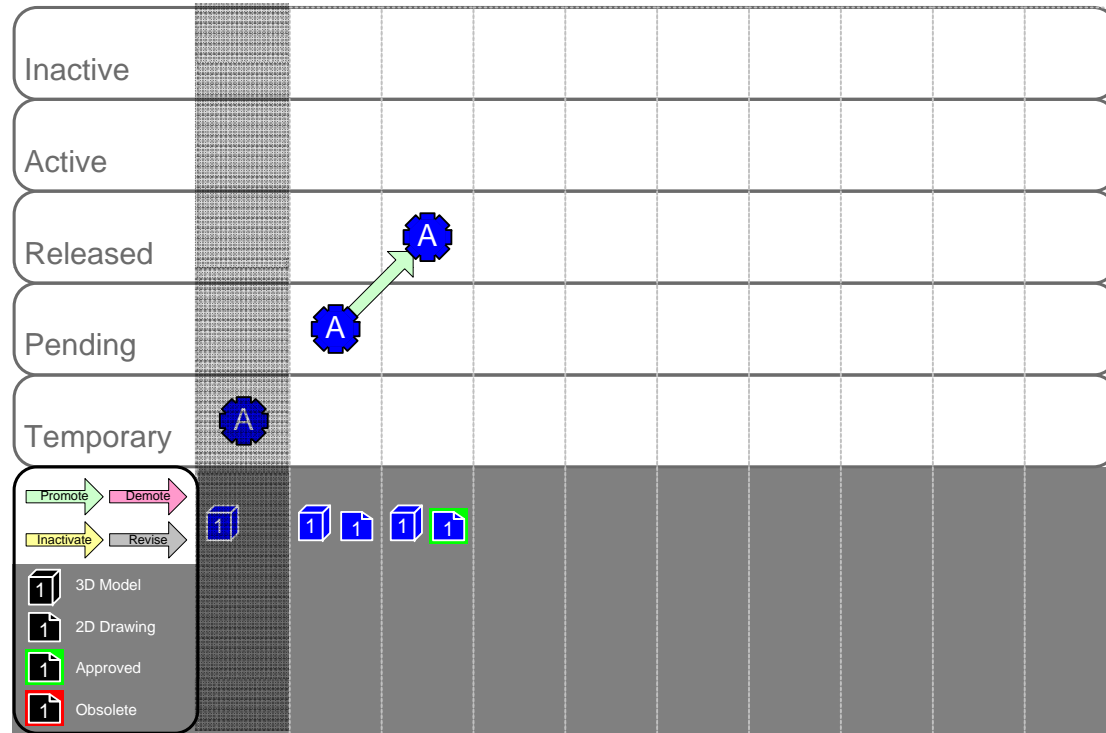

# Scenario

- ▶ Problems found during tooling development
- ▶ New revision needed for Part
- ▶ Part rev A made “inactive”
- ▶ Old drawing made obsolete
- ▶ New 3D and 2D prepared

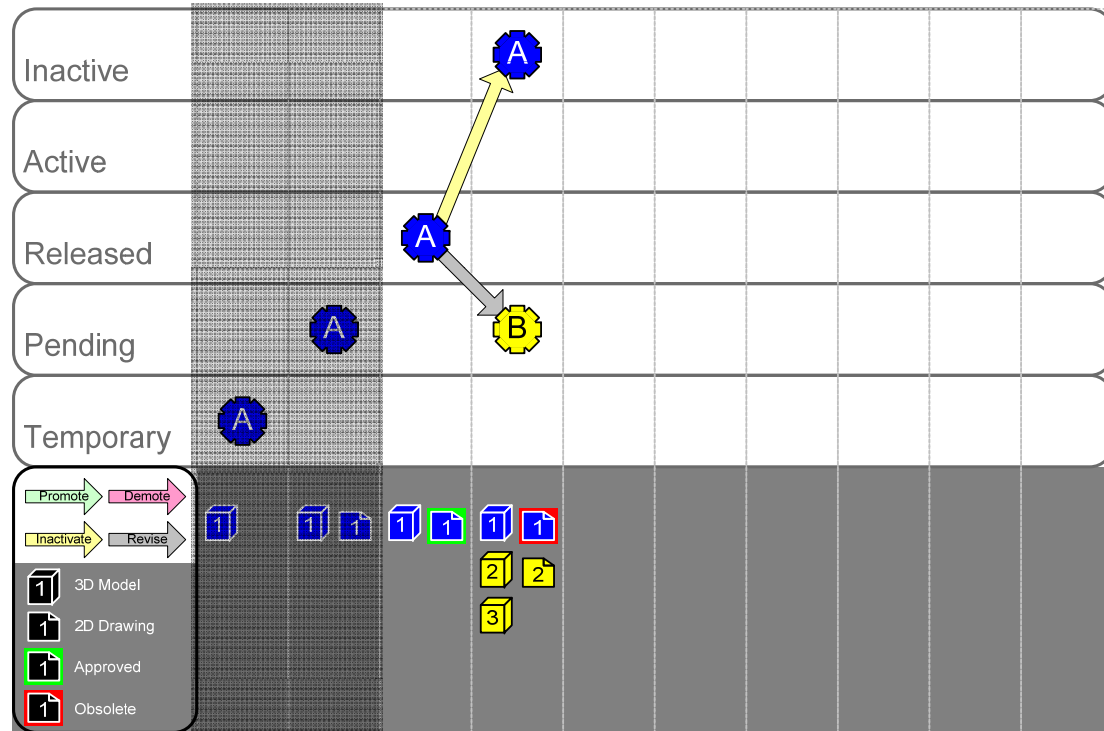

# Scenario

- ▶ Specifying drawing reviewed and approved
- ▶ Part rev B promoted from “pending” to “released”

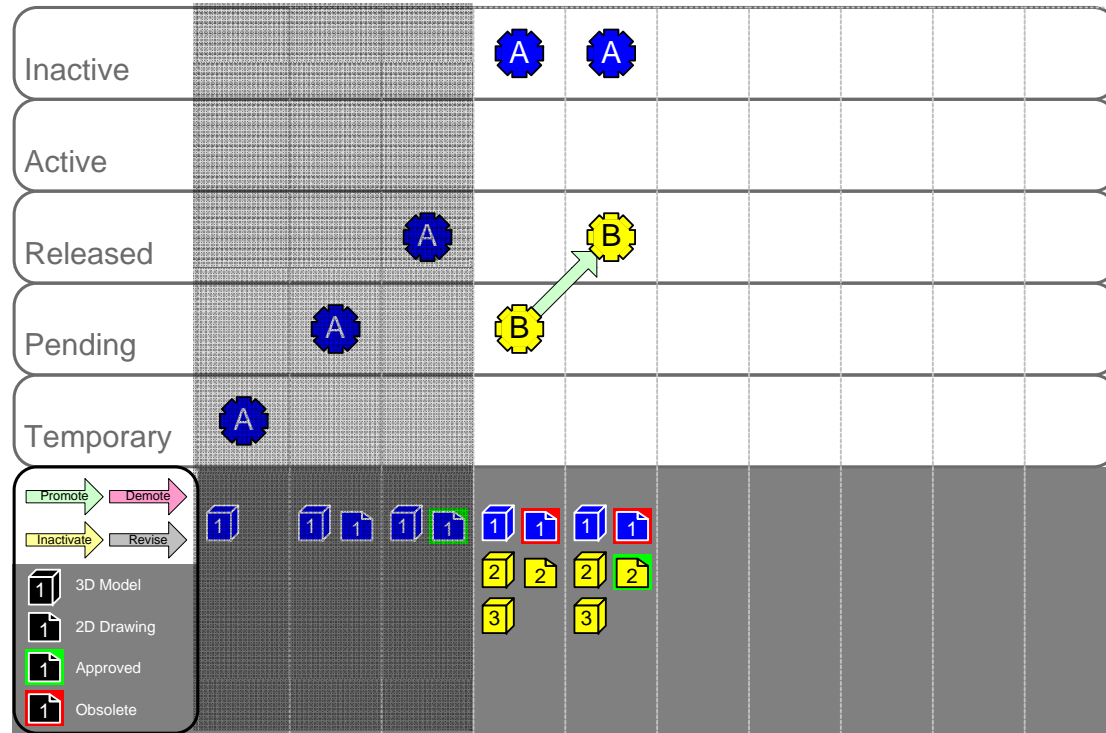

# Scenario

- ▶ Tooling completed
- ▶ Part rev B promoted from “released” to “active”
- ▶ Production begins

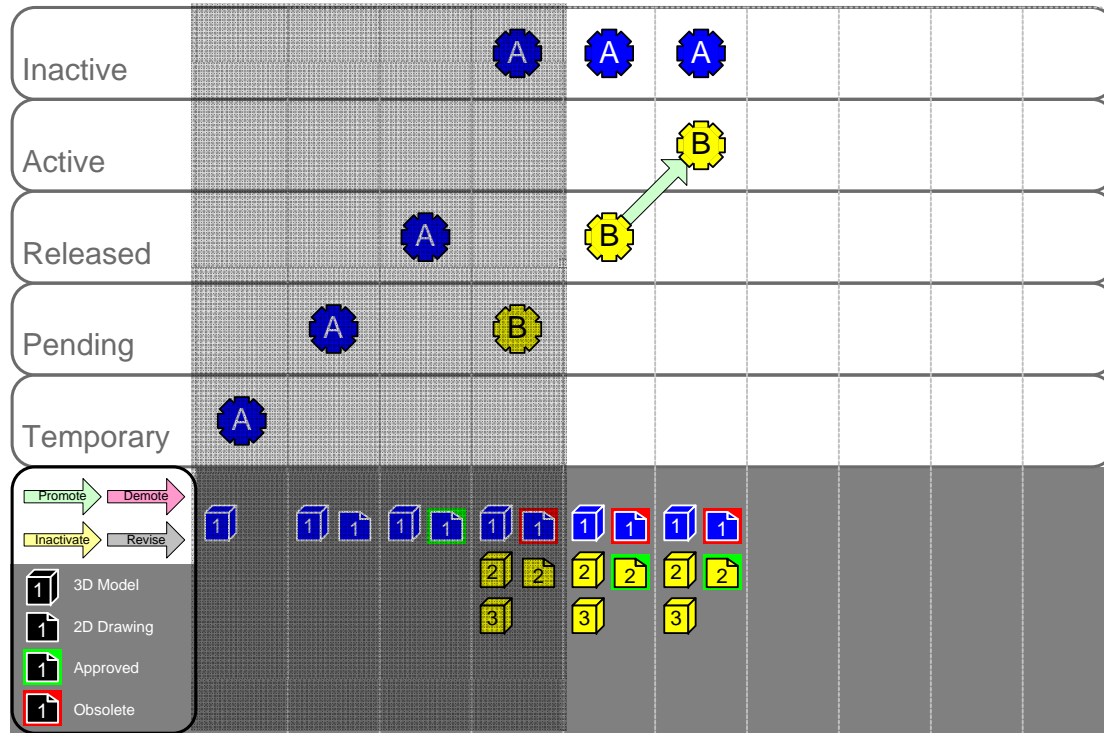

# Scenario

- ▶ Part redesign initiated for cost savings program
- ▶ New revision needed (rev C)
- ▶ New 3D and 2D prepared

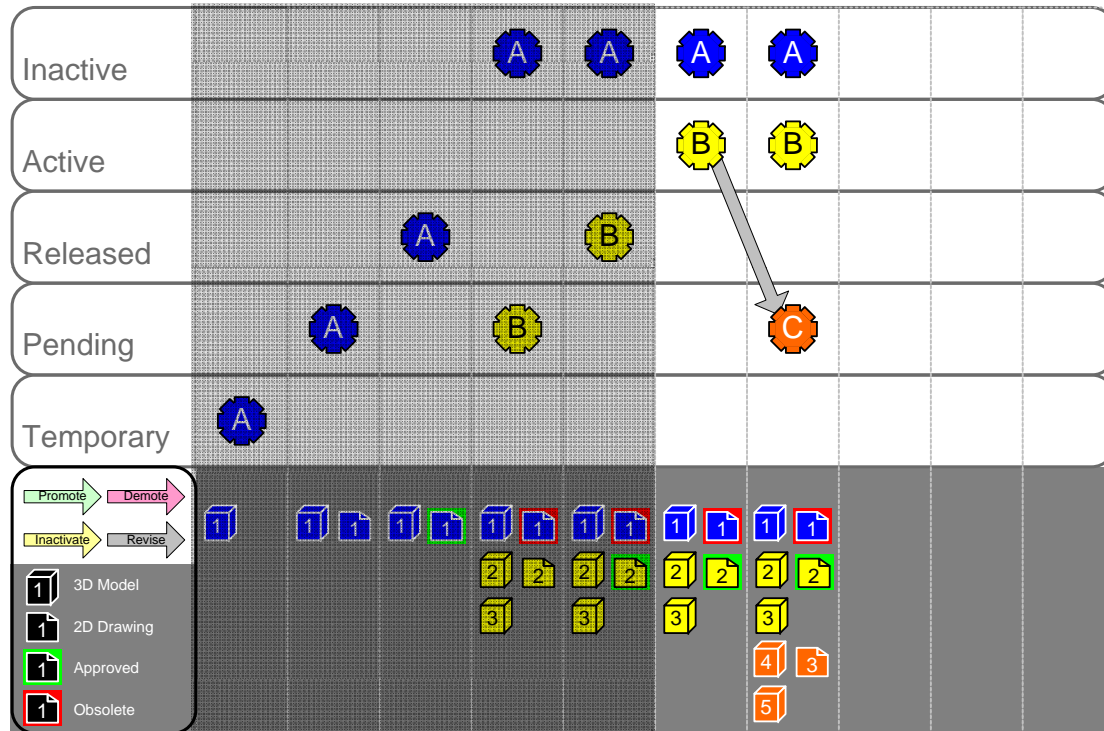

# Scenario

- ▶ New 2D drawing approved
- ▶ Part rev C promoted from “pending” directly to “active”
- ▶ 2 revisions of the Part in production at one time

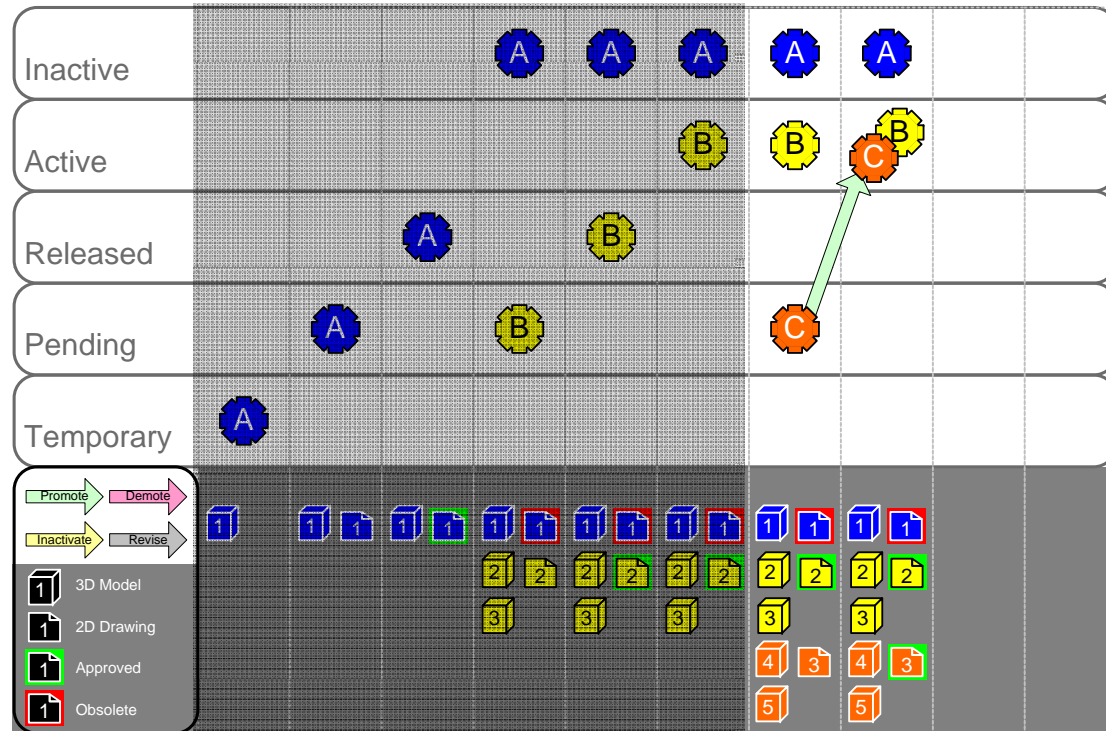

# Scenario

- ▶ Part rev B demoted to “released” after inventory depleted

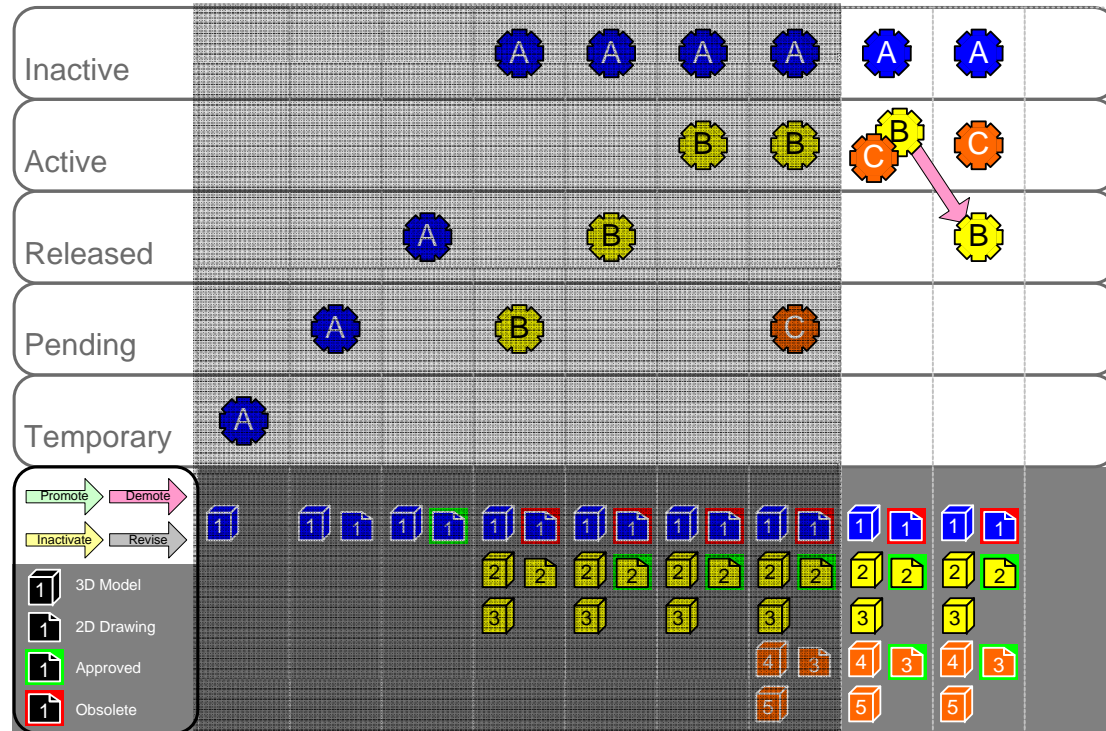

# Scenario

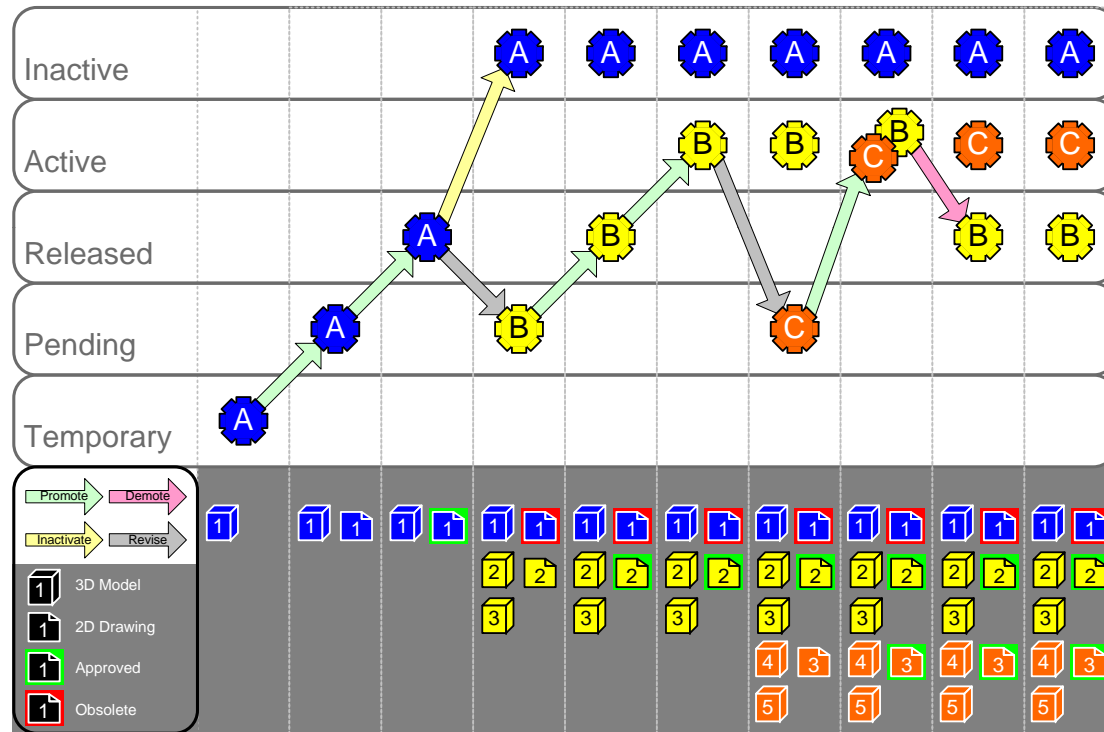



*Thank You*

# Eric Smith



[www.Razorleaf.com](http://www.Razorleaf.com)



[Eric.Smith@Razorleaf.com](mailto:Eric.Smith@Razorleaf.com)



330.676.0022 x7135

